



ProLite T1931SR-1 is based on the latest 5 Wire Resistive technology. Price / performance ratio is ideal for the budget conscious user while quality and specification is certainly not compromised. The display inputs include both Analogue and Digital (DVI) with Touchscreen connectivity via either USB or RS-232 which offers greater than typical flexibility. A solid and steady base supports the TouchScreen with an adjustable stand offering full 90 degree angles. Extensive Touch Utilities allow for 4 point calibration and either 9/25 point linerization. An incredibly powerful Touch solution. Available in black and white.



TOUCH TECHNOLOGY - RESISTIVE

5-wire resistive touchscreens are very durable and can be used in a variety of environments. They are especially recommended for shops, restaurants and industrial purposes.



IP54

The IP Code classifies how resistant a device is to foreign objects and moisture. IP54 means that the monitor will operate in dusty conditions, and will resist splashing water.

1. DISPLAY CHARACTERISTICS

DIAGONAL	19"; 48cm
TOUCHTECHNOLOGY	resistive
PANEL	TN
DISPLAY AREA H X W	301 x 376 mm; 11.9" x 14.8"
RESPONSE TIME	5 ms
CONTRAST	900 : 1 with touch panel
BRIGHTNESS	200 cd/m ² with touch panel
VIEWING ZONE	horizontal/vertical: 170°/ 160°; right/left: 85°/ 85°; up/down: 80°/ 80°
DISPLAY COLOUR	16.7 million
PIXEL PITCH H X V	0.294 x 0.294 mm
NATIVE RESOLUTION	1280 x 1024 (1.3 megapixel)
HORIZONTAL SYNC	31.5 - 80 KHz
VERTICAL SYNC	56 - 75 Hz
SYNCHRONIZATION	Separate Sync
ASPECT RATIO	5 : 4
LIGHT TRANSMITTANCE	80%

2. INTERFACES & CONNECTORS

ANALOG INPUT CONNECTOR	VGA
DIGITAL INPUT CONNECTOR	DVI-D
INPUTS	USB, RS-232C

3. SPECIAL FEATURES

APPLE - MAC	OS9, OSX
PLUG & PLAY	VESA DDC 2B™
CONTROLS	On-Screen-Display in 8 languages (DE, EN, ES, FR, IT, JP, Chinese - traditional and simplified) and 5 front controls (Menu, Scroll up/ Brightness, Scroll down/ Mute, Select/ Auto, Power)
USER CONTROLS	contrast, brightness, auto adjust, H.position, V.position, H.size, phase, OSD H.position, OSD V.position, OSD timeout, reset, input select, OSD language, colour temperature, volume, mute
SPEAKERS	2 x 1 W (Stereo)
ANTI-THEFT-DEVICE	Kensington-lock™ prepared
SAFETY	CE, CB, TÜV-Bauart, Gost-R, VCCI, IP54
TILT ANGLE	90° up; 5° down
VESA MOUNTING	100 x 100 mm
COLOUR	Black

4. ACCESSORIES

DRIVER	Windows (Vista, XP, 9X, 2000, CE, NT4), Linux, Mac (OSX, OS9), DOS
INCLUDED ACCESSORIES	power cable, D-Sub signal cable, DVI-D signal cable, RS-232C signal cable, audio cable, USB cable, Touch Panel Driver Disk (CD-ROM), screw, quick start guide

5. POWER MANAGEMENT

POWER SUPPLY	AC 100 - 240 V, 50 / 60 Hz
POWER SUPPLY UNIT	internal
POWER USAGE	25 W typical; max. 2 W in Power management mode
POWER MANAGEMENT	VESA DPMS

6. DIMENSIONS & WEIGHT

DIMENSIONS W X H X D	432 x 390 x 218 mm
WEIGHT	6.6 kg

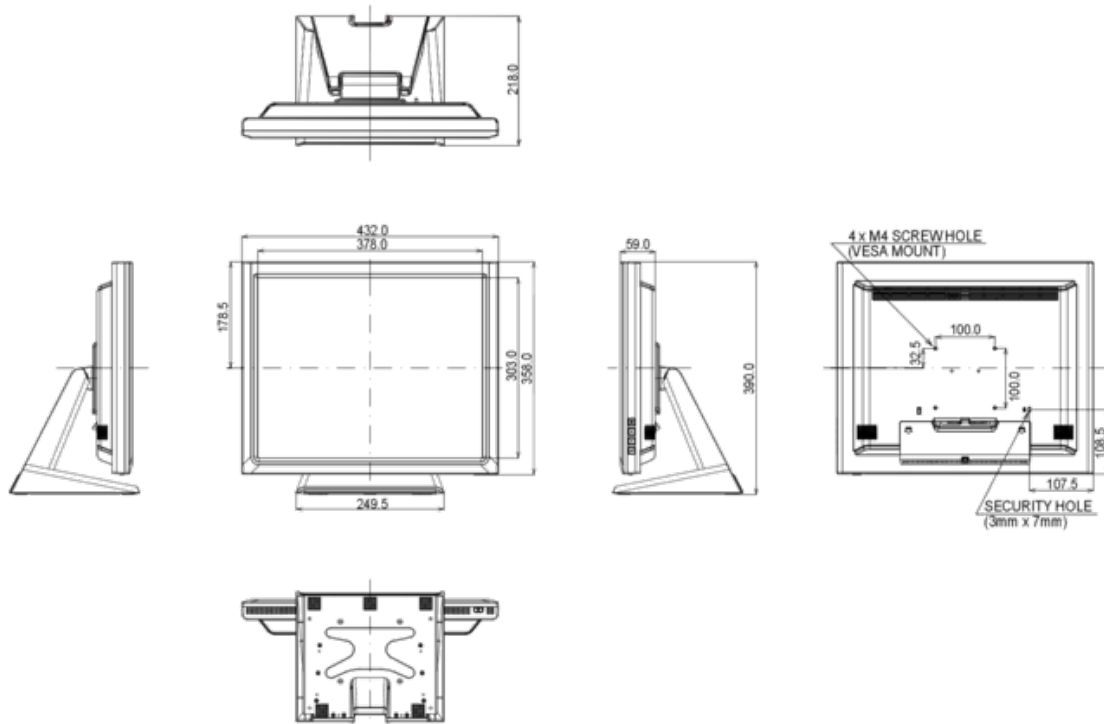

All trademarks acknowledged. Errors and changes reserved. Product specifications are subject to change without notice. All LCD's comply with ISO-13406-2 which specifies the number and type of pixel defects.